

RIG 43



Primary Equipment



Major Systems	Secondary Systems
Drawworks NOV ADS-10SD 1500HP AC drwks with ReGen Braking capacity NOV Software limited 625,000# Hoisting Capacity (10) lines w/2-AC 1150HP motor input/Gear drive	Air/ Actuated, Park Disc
Prime Power NOV DrillForce LT VFD "Ideal" System with Amphoin Drillers control cabin 3-Caterpillar 3512-C w/Kato 1265 KW AC Generator Dual Fuel Capable	1-3/8"WireRope 6 x 19 EIP IWRC
Mast/Substructure NOV 142' 750,000# Hook load, Slingshot Design 25' Sub w/RKB 21.8' Crown Block 5-50" Sheaves 1-3/8" Groove Fastline 1-60" 1-3/8" Groove 2- 42" deadline sheaves	Cold Start air system, primary Rig Air supply, floor hoisting systems
Top Drive - Traveling Block - Pipe Handling NOV TDS 11SA AC 500 Ton Top Drive NOV 500 Ton Traveling Block NOV 37 1/2" Rotary Table w/400HP AC motor NOV ST-80CL pipe handling system CanRig Hydraulic Catwalk	Fuel Capacity 20,000gal & Water Storage Capacity 400bbl
Mud Pumps 2-National 12-P-160 1600HP Triplex, 7500PSI w/7,500#WP Fluid ends and delivery system each driven by 2-1150HP AC motors	Rotary load 750,000# Set Back 500,000#
Mud System 2 -Tank system (1,314bbl Capacity), 100 Trip Tank w/ 100bbl Trip Tank 2 -NOV King Cobra Hydro Shale Shakers	Tool Pusher and Crew quarters, rig matting boards
BOP Stack Description 13 5/8" 5,000# Annular 13 5/8" 5,000# Double Ram	NOV Steel Toe Walking systems incorporated within lower substructure base
Drill String 8' and 6-1/2" Drill Collars 5" Drill Pipe	Manual Tongs, elevators, slips and clamps for Latshaw supplied DS
	NOV BOP Control Model L200-T6EA30CE2 3,000PSI Accumulator, 180 gal, 6 station w/remote
	7-NOV MA-10 10HP Mud Agitators
	NOV DSN-3V-10CTX 3-10" cone Desander 1500gpm
	NOV Model DSLR-20GG-4CTX Desilter 20-4" cone Desilter
	Type FC 4-1/1"6 10,000# x 3-1/8"10,000# Choke Manifold
	NOV Model DG-10 Degasser
	5" 19.5# G-105 & S135
	Heavy weight Drill pipe

Annular

13 5/8" 5,000#WP

Double Ram

13 5/8' 5,000#WP Pipe

13 5/8' 5,000#WP Blind

With required adaptors

Mud Cross 13 5/8" 5,000#WP

Wing Valve 4 1/16" 5'000#WP

HCR Valve 4 1/16" 5,000#WP

2-Kill Valves 2 1/16" 5,000#WP

Check Valve 2 1/16" 5,000#WP

Choke Line 4 1/16" 5M Armored

Kill Line 2 1/16" 5M Armored

RIG 43

Latshaw
DRILLINGTM

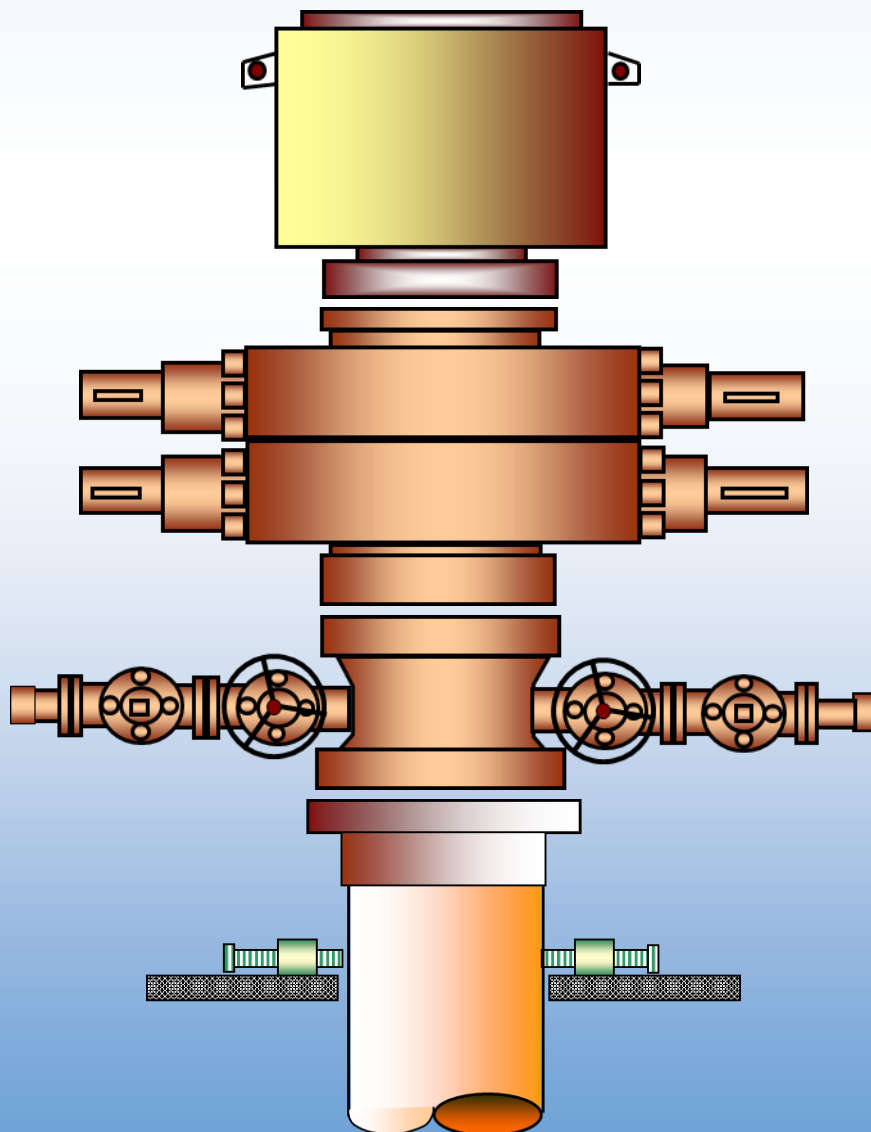

Operator Supplied
Hydraulic Chokes

RIG 43

Latshaw
DRILLING™

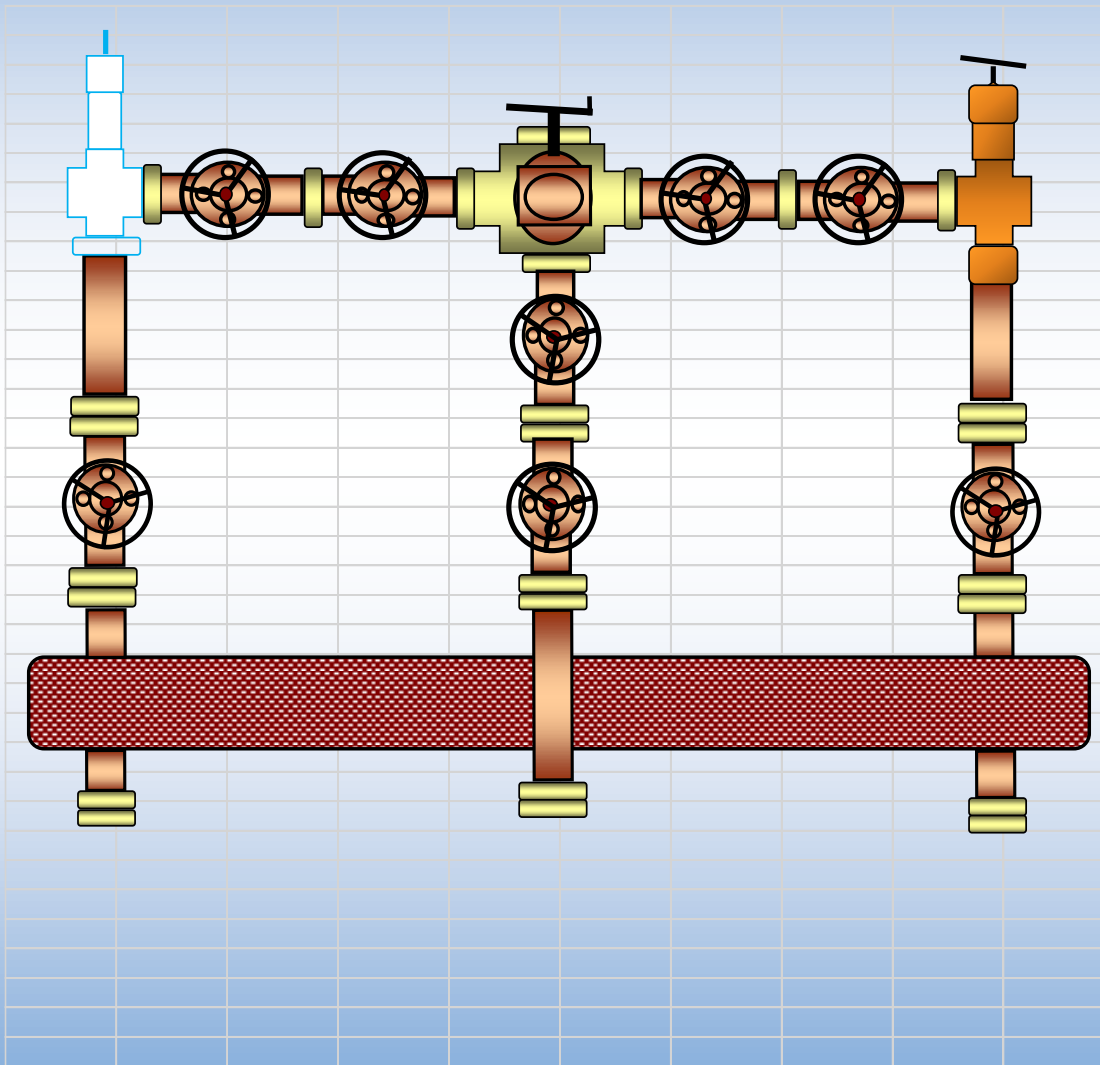

- 2- Gate Valve 4 1/16" 10,000#WP
- 4 - Gate Valve 3 1/16" 10,000#WP
- 2 - Gate Valves 3 1/8" 10,000#WP
- 1- Gate Valve 2 1/16" 10,000#WP
- 1 - Manual Adjustable Choke 3 1/10"
10,000#WP
- 1 - DSA, 3 1/16" 10,000#WP
- 1- Spacer Spool, 3 1/8" 10,000#WP
- 1 - Studded Cross (5way) 10,000#WP
- 1 - Instrument Flange and Gauge
- 10 3/4" Buffer Chamber

IF IN DOUBT...ASK!

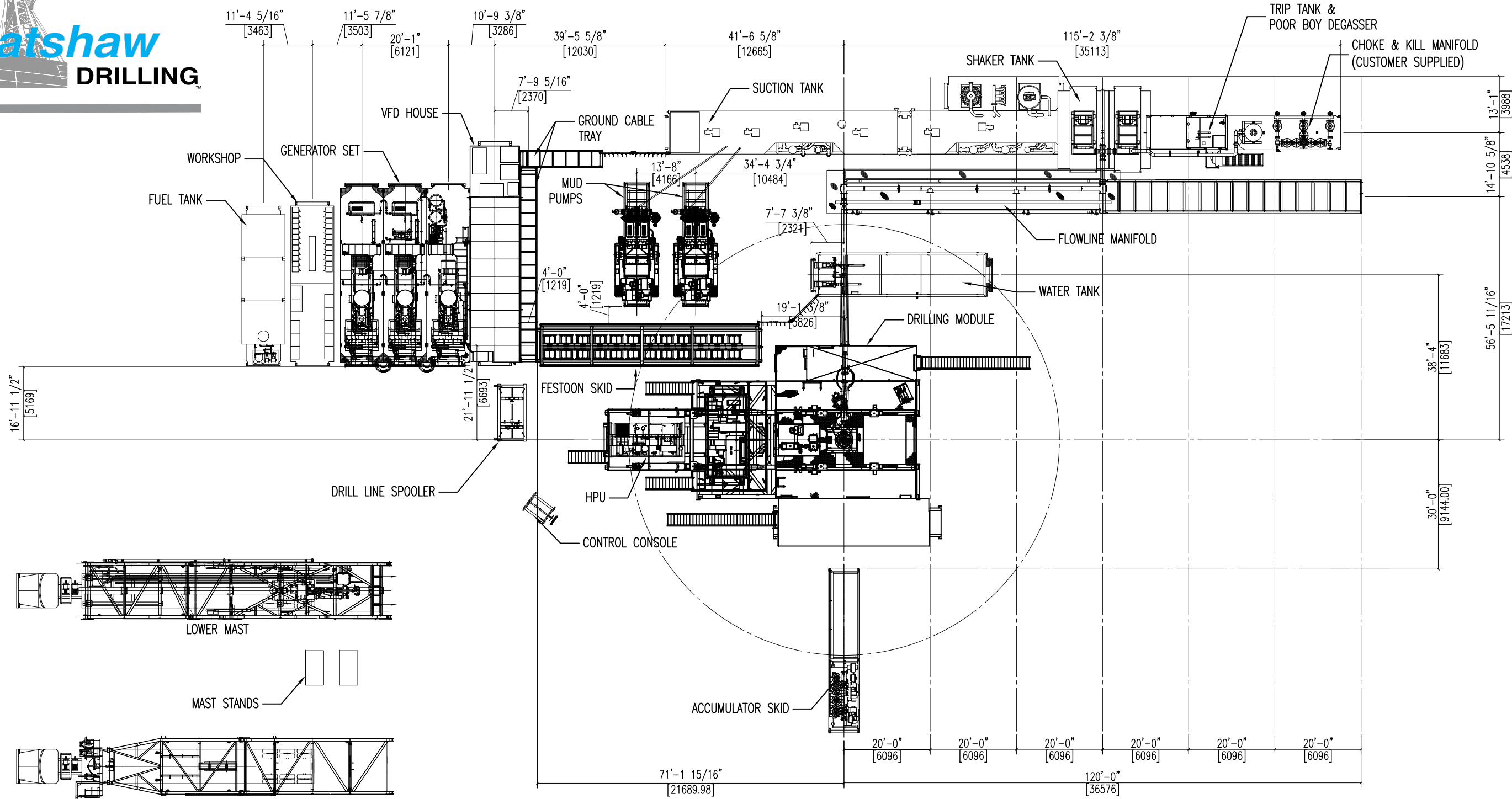

- NOTES:**
1. Drilling Module should be located at Well #2 during rig up to avoid interference with backyard equipment while rig floor is in the lowered position.
 2. Choke Manifold will be supplied by the customer; Pictured item is NOV's choke manifold.
 3. General Arrangement is preliminary and for reference purposes only. Specific locations of equipment relative to well center and other equipment subject to change. Unreleased assemblies subject to design changes.

04					
03					
02					
01	09-23-14	ISSUED FOR CONSTRUCTION	CDH	YLW	CDH
REV	DATE	DESCRIPTION	MADE	CHKD	APRD

DIMENSIONS & TOLERANCES

FRACTIONAL ± 1/16	POSITION Ⓢ 0.005in
CASTINGS ± 1/16	CONCENTRICITY Ⓞ 0.005in TIR
ANGULAR ± 1°	STRAIGHTNESS — 0.005in/5 inches
0.0 ± 0.030	FLATNESS ▯ 0.005in/5 inches
0.00 ± 0.015	PARALLELISM // 0.010in/5 inches
0.000 ± 0.005	PERPENDICULARITY ⊥ 0.010in/10 inches

PROJECT:
CUSTOMER:
ITP:
SHOP W/O:
DATE:

NOV NATIONAL OILWELL VARCO

THIS DOCUMENT CONTAINS PROPRIETARY AND CONFIDENTIAL INFORMATION WHICH BELONGS TO NATIONAL OILWELL VARCO, L.P., ITS AFFILIATES OR SUBSIDIARIES (ALL COLLECTIVELY REFERRED TO HEREINAFTER AS "NOV"). IT IS LOANED FOR LIMITED PURPOSES ONLY AND REMAINS THE PROPERTY OF NOV. REPRODUCTION, IN WHOLE OR IN PART, OR USE OF THIS DESIGN OR DISTRIBUTION OF THIS INFORMATION TO OTHERS IS NOT PERMITTED WITHOUT THE EXPRESS WRITTEN CONSENT OF NOV. THIS DOCUMENT IS TO BE RETURNED TO NOV UPON REQUEST AND IN ANY EVENT UPON COMPLETION OF THE USE FOR WHICH IT WAS LOANED. THIS DOCUMENT AND THE INFORMATION CONTAINED AND REPRESENTED HEREIN IS THE COPYRIGHTED PROPERTY OF NOV.

RIG PACKAGE GROUP
11000 CORPORATE CENTRE DR.
HOUSTON, TEXAS 77041

TITLE:
**RIG GENERAL ARRANGEMENT
IDEAL RIG - 120' SINGLE ROW**

SCALE: PROJECTION: SIZE: D MAIN PART:
DRAWING NUMBER: 11042514-GAD SHEET: 1 of 3 REVISION: 01

DWG NO 11042514-GAD SH 1

DWG NO 11042514-GAD SH 1

C

B

A

IF IN DOUBT...ASK!

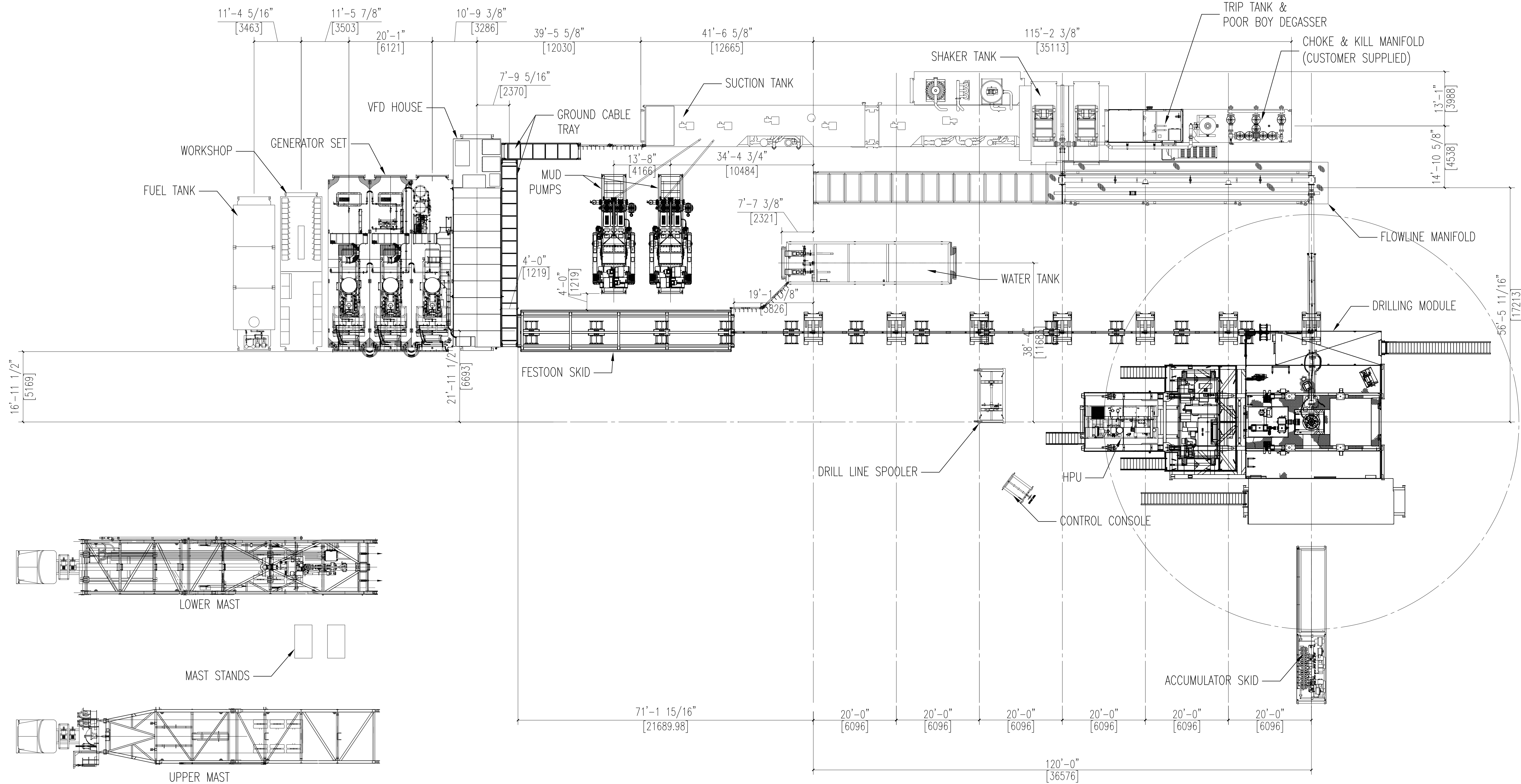

- NOTES:**
1. Drilling Module should be located at Well #2 during rig up to avoid interference with backyard equipment while rig floor is in the lowered position.
 2. Choke Manifold will be supplied by the customer; Pictured item is NOV's choke manifold.
 3. General Arrangement is preliminary and for reference purposes only. Specific locations of equipment relative to well center and other equipment subject to change. Unreleased assemblies subject to design changes.

REV	DATE	DESCRIPTION	MADE	CHKD	APRD
04					
03					
02					
01	09-23-14	ISSUED FOR CONSTRUCTION	CDH	YLV	CDH

DIMENSIONS & TOLERANCES

FRACTIONAL ± 1/16	POSITION ± 0.005in
CASTINGS ± 1/16	CONCENTRICITY ± 0.005in TIR
ANGULAR ± 1'	STRAIGHTNESS 0.005in/5 inches
0.0 ± 0.030	FLATNESS ± 0.005in/5 inches
0.00 ± 0.015	PARALLELISM // 0.010in/5 inches
0.000 ± 0.005	PERPENDICULARITY ⊥ 0.010in/10 inches

PROJECT:
CUSTOMER:
ITP:
SHOP W/D:

DATE:

GA SPECIFICATION INFORMATION



THIS DOCUMENT CONTAINS PROPRIETARY AND CONFIDENTIAL INFORMATION WHICH BELONGS TO NATIONAL OILWELL VARCO, L.P., ITS AFFILIATES OR SUBSIDIARIES (ALL COLLECTIVELY REFERRED TO HEREINAFTER AS "NOV"). IT IS LOANED FOR LIMITED PURPOSES ONLY AND REMAINS THE PROPERTY OF NOV. REPRODUCTION, IN WHOLE OR IN PART, OR USE OF THIS DESIGN OR DISTRIBUTION OF THIS INFORMATION TO OTHERS IS NOT PERMITTED WITHOUT THE EXPRESS WRITTEN CONSENT OF NOV. THIS DOCUMENT IS TO BE RETURNED TO NOV UPON REQUEST AND IN ANY EVENT UPON COMPLETION OF THE USE FOR WHICH IT WAS LOANED. THIS DOCUMENT AND THE INFORMATION CONTAINED AND REPRESENTED HEREIN IS THE COPYRIGHTED PROPERTY OF NOV.

RIG PACKAGE GROUP
11000 CORPORATE CENTRE DR.
HOUSTON, TEXAS 77041

TITLE:
**RIG GENERAL ARRANGEMENT
IDEAL RIG - 120' SINGLE ROW**

SCALE: PROJECTION: SIZE: D MAIN PART:

DRAWING NUMBER: 11042514-GAD SHEET: 2 of 3 REVISION: 01

IF IN DOUBT...ASK!

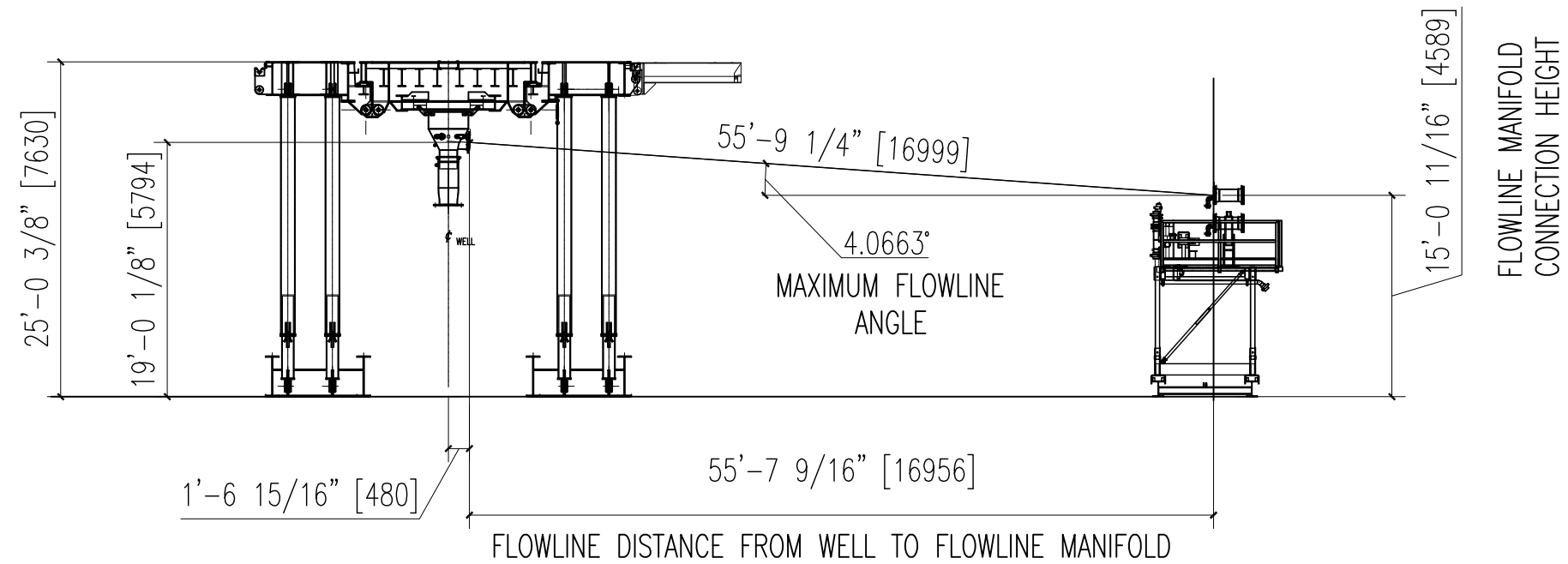

FLOWLINE MANIFOLD CONNECTION HEIGHT

FLOWLINE DISTANCE FROM WELL TO FLOWLINE MANIFOLD

NOTES:
1. General Arrangement is preliminary and for reference purposes only. Specific locations of equipment relative to well center and other equipment subject to change. Unreleased assemblies subject to design changes.

REV	DATE	DESCRIPTION	MADE	CHKD	APRD
04					
03					
02					
01	09-23-14	ISSUED FOR CONSTRUCTION	CDH	YLW	CDH

GA SPECIFICATION INFORMATION	
DIMENSIONS & TOLERANCES FRACTIONAL ± 1/16 POSITION ⊕ 0.005in CASTINGS ± 1/16 CONCENTRICITY ◎ 0.005in TIR ANGULAR ± 1° STRAIGHTNESS — 0.005in/5 inches 0.0 ± 0.030 FLATNESS ▯ 0.005in/5 inches 0.00 ± 0.015 PARALLELISM // 0.010in/5 inches 0.000 ± 0.005 PERPENDICULARITY ⊥ 0.010in/10 inches	

PROJECT:
CUSTOMER:
ITP:
SHOP W/O:
DATE:



THIS DOCUMENT CONTAINS PROPRIETARY AND CONFIDENTIAL INFORMATION WHICH BELONGS TO NATIONAL OILWELL VARCO, L.P., ITS AFFILIATES OR SUBSIDIARIES (ALL COLLECTIVELY REFERRED TO HEREINAFTER AS "NOV"). IT IS LOANED FOR LIMITED PURPOSES ONLY AND REMAINS THE PROPERTY OF NOV. REPRODUCTION, IN WHOLE OR IN PART, OR USE OF THIS DESIGN OR DISTRIBUTION OF THIS INFORMATION TO OTHERS IS NOT PERMITTED WITHOUT THE EXPRESS WRITTEN CONSENT OF NOV. THIS DOCUMENT IS TO BE RETURNED TO NOV UPON REQUEST AND IN ANY EVENT UPON COMPLETION OF THE USE FOR WHICH IT WAS LOANED. THIS DOCUMENT AND THE INFORMATION CONTAINED AND REPRESENTED HEREIN IS THE COPYRIGHTED PROPERTY OF NOV.

RIG PACKAGE GROUP 11000 CORPORATE CENTRE DR. HOUSTON, TEXAS 77041	
TITLE: RIG GENERAL ARRANGEMENT IDEAL RIG - 120' SINGLE ROW	
SCALE:	PROJECTION:
DRAWING NUMBER: 11042514-GAD	SIZE: D MAIN PART:
SHEET: 3 of 3	REVISION: 01

DWG NO 11042514-GAD SH 1

DWG NO 11042514-GAD SH 1